

Development and optimization of process chains for the micro mold industry: technological limits of the micro milling and micro die-sinking EDM technologies

E. Uhlmann^{1,2}, D. C. Domingos¹, S. Kühne², A. Zanatta³, J. de O. Gomes⁴

¹Fraunhofer Institute for Production Systems and Design Technology IPK, Germany

²Institute for Machine Tools and Factory Management IWF, Technische Universität Berlin, Germany

³SENAI Institute of Innovation for Manufacturing Systems, Brazil

⁴Competence Center for Manufacturing CCM, Aeronautics Institute of Technology ITA, Brazil

david.carlos.domingos@ipk.fraunhofer.de

Abstract

The mold-making industry faces nowadays the challenge of selecting the appropriate manufacturing technology for machining micro molds, normally made of high strength and difficult-to-machine steels. This selection of appropriate technology shall consider the productivity, the involved costs, the operating times, form accuracy and surface quality. The industry producing micro molds is facing the challenge of choosing from two technologies available: the micro milling and the die-sinking μ -EDM. With regard to identical cavities, experiments were conducted aiming the comparison of the technological limitations for both technologies, micro milling and die-sinking μ -EDM, in respect to form accuracy of parts, surface quality and machining time.

Keywords: Micro molds, micro milling, μ -EDM machining and dental products

1. Introduction

Precision components e.g. for die and mould fabrication can be produced by micro milling or die sinking EDM in different kinds of materials and with high geometrical flexibility. The two methods compete in quality, production time and cost effectiveness. Micro milling technology is characterized by high flexibility of work piece shapes and low processing times, if compared to the EDM technology. The process is limited by the work piece's hardness, which leads to high tool wear and sometimes premature tool breakage [1, 2].

The die-sinking μ -EDM is characterized by low productivity and long machining times. However, μ -EDM enables the machining of all electrical conductive materials, independent of the mechanical properties of workpieces such as hardness. This technology also enables the fabrication of high complex surfaces with high surface quality. Finally, the EDM technology is considered a process with almost non-existing machining forces, enabling this for micro manufacturing tasks [3].

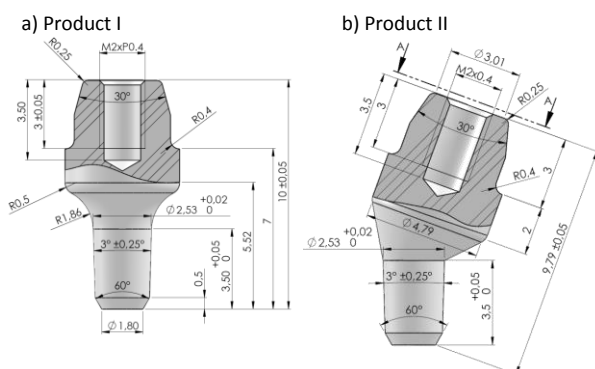

Figure 1. Dimensions and tolerances of the products

For a direct comparison, both technologies were used to produce the same sample product with regard to the mentioned criteria. The chosen products are dental provisional abutments with required tolerances down to 5 μ m, shown in

Figure 1 and Figure 2. The high-grade stainless steel Böhler M340 Isoplast (54 HRC) was defined as material of the micro mold. Experiments were conducted aiming the comparison of the technological limitations of both technologies, namely micro milling and die-sinking μ -EDM, in respect to form accuracy of parts, surface quality and machining time.

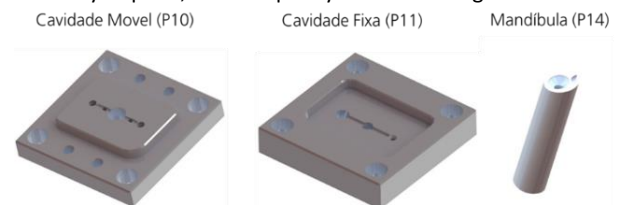

Figure 2. 3D design of the micro mold with cavities

2. Results and discussion

Two process chains for manufacturing the completely identical cavities were designed and tested. In process chain 1 the micro milling was applied for producing the cavities at the molds. In process chain 2 the micro milling and micro turning technologies were used for producing tool electrodes, which were then applied in the die-sinking μ -EDM. To measure the achieved quality for the validation of the produced parts the Zeiss O-Inspect 442 coordinate measuring device was applied. The Hommel Nanoscan 855 tactile measuring system was used for the surface roughness measurements.

2.1. Process Chain 1 (PC1)

Process chain 1 applies the micro milling technology to machine the cavities. The complete process chain is divided as the following: heat treatment, pre-machining (micro milling / die-sinking μ -EDM / μ -wire-EDM) and finally micro-milling of the cavities. The milling operation of the cavities will be analysed and discussed in this paper. The machine tool used for micro milling processes is a Primacon PFM 4024 5D. The applied milling tools have a better performance if the

lubrication is reduced or even completely removed. The overall machining time applying improved process parameters was 14 min for Cavidade Fixa and 41 min for Cavidade Movel. The applied tools and parameters are shown in **Table 1** and **Table 2**.

Table 1. Production parameters for cavidade movel

Operation	Tool	RPM [1/min]	Feed [mm/min]	Overmeasure [mm]	Time [min]
Roughing	C 2mm	22 000	450	0.03	1
Finishing	TC 1x0.25mm	45 000	250	0.00	13

Table 2. Production parameters for Cavidade Fixa

Operation	Tool	RPM [1/min]	Feed [mm/min]	Overmeasure [mm]	Time [min]
Roughing	EM 2mm	19 000	750	0.02	1
Finishing	TC 1x0.25mm	45 000	250	0	40

Measurements confirmed that the tool wear is the major problem while micro milling hardened tool steel. For sequentially produced cavities the deviations are grown continuously as shown in **Figure 3**. The wear behaviour leads to unpredictable tool life and quality of the work pieces even with coated tools [2]. The achieved roughness is strongly influenced by the wear and it varied from Ra = 140 nm to Ra = 741 nm. By the beginning of the operations, the roughness achieved by applying new tools was worse than the roughness achieved while using worn tools. However, with increasing duration of machining time, the surface roughness gets worse again. Process reproducibility is therefore very limited. In respect of the tolerances a new tool should be used for every finishing process to stay competitive.

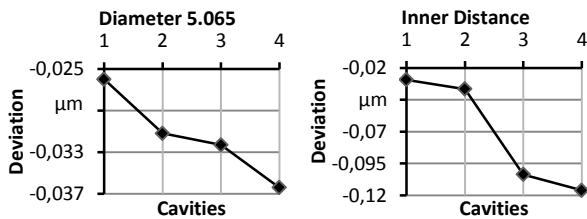

Figure 3. Dimension deviations for sequentially produced cavities

The beneficial of a cutting edge preparation [3] on wear and roughness must be examined in the future. In **Table 4** the achieved results regarding to tolerances are shown. The tolerances for the free-form radii and the chamfer angle of 30° were challenging to be achieved. The angle is already out of the tolerance with a small absolute deviation of 5 µm on the short length from the chamfer. The same is applicable for the shape radii. An absolute deviation of 5 µm would also lead to a deviation of the radius that exceeds the required tolerance.

2.2. Process Chain 2 (PC2)

Process chain 2 applies the die-sinking µ-EDM technology to machine the cavities. This process chain contains following sub-processes: heat treatment, pre-machining (micro milling / die-sinking µ-EDM / µ-wire-EDM), micro milling and micro-turning of electrodes and finally µ-EDM of the cavities. The EDM machine Genius 1000 THE CUBE was applied in the experiments, together with electrodes made of electrolyte-copper E-Cu 58. The workpiece material was the same as in PC1. **Table 3** presents the applied EDM technologies (roughing, smoothing and polishing) and the most relevant process parameters. The total machining time for Cavidade Fixa was 56 min for roughing and finishing and 3 hours for polishing, while the machining time for Cavidade Movel was 56 min for roughing and finishing and 2 hours for polishing. The longer polishing time applied for Cavidade Fixa is due to the functional surface this workpiece possesses, which had requirements for precision and good surface roughness. The surface roughness Ra achieved applying µ-EDM was Ra = 183 ± 11 nm and this was

below the required Ra < 200 nm. The machining time for producing the electrodes was not considered here.

Table 3. Applied EDM technologies and parameters

Operation	t _i [µs]	t ₀ [µs]	i _c [A]	ū _i [V]	Polarity	Discharge type	C _c [nF]
Roughing	60	60	4.9	120	+	Static pulse	
Finishing	10	25	1.5				
Polishing	2	3	0.35	90	-	Relaxation	100

2.3. Metrology Results

Table 4 presents some metrology results of produced cavities applying both process chains. The most critical features for both workpieces and each process chain are presented here. The deviations lying outside the tolerances are presented in red. Process chain 1 applying micro milling presented more deviations than process chain 2 applying µ-EDM. The main difficulties by micro milling were observed in the machining of free-forms (simultaneous multi-axis), especially for curved surfaces and angles, which can result from the programming of such machining paths.

Table 4. Metrology results

Cavidade Movel	Setpoint	Tolerance	Deviation PC1	Deviation PC2
Diameter (1) [mm]	5.065	± 0.05	-0.0292	0.008
Diameter (2) [mm]	5.065	± 0.05	-0.0379	-0.005
Angle (1) [°]	30°	± 0.3	0.4323	-0.038
Angle (2) [°]	30°	± 0.3	-0.1124	0.153
Inner Distance X (1) [mm]	4.254	± 0.05	-0.0308	-0.007
Inner Distance X (2) [mm]	4.254	± 0.05	-0.027	-0.008
Cavidade Fixa	Setpoint	Tolerance	Deviation PC1	Deviation PC2
Radius [mm]	1.879	± 0.02	-0.138	-0.007
Angle [°]	1.50°	± 1	0.282	-0.066
Radius 0.507 [mm]	0.5065	± 0.02	-0.0078	-0.212

4. Summary

The overall machining time for producing both cavities in the micro mold showed that the micro milling process can be much faster than µ-EDM. However, the results achieved by micro milling were more often outside the given tolerances, both for dimensional and form accuracy as well as for surface roughness Ra. The surface roughness Ra after micro milling process was varying strongly, limiting therefore the process stability.

A further investigation for a detailed comparison of the process chains is necessary. Process results within given tolerances have to be achieved applying both process chains, and after that the comparison can be carried out. The approach of improving the programming of the simultaneous multi-axis micro milling will be followed, as well as a detailed investigation on tool wear for achieving good surface roughness Ra. An approach can be the utilization of a cutting edge preparation process, guaranteeing a reproducible and more stable process. The focus for further improvement on µ-EDM will be on improving or reducing the polishing times necessary for achieving good surface roughness Ra < 200 nm.

References

- [1] Uhlmann, E.; Mahr, F.; Loewenstein, A.; Raue, N.; Oberschmidt, D.: Performance Characteristics of Coated Micro Milling Tools. *7th Balkan Trib Conference* (2011), Thessaloniki, Greece.
- [2] Uhlmann, E.; Oberschmidt, D.; Kuche, I.; Loewenstein, A.: Cutting Edge Preparation of Micro Milling Tools, *6th CIRP International Conference on High Performance Cutting*, Procedia CIRP 14 (2014), p. 349-354.
- [3] Uhlmann, E.; Piltz, S.; Doll, U.: Machining of micro/miniature dies and moulds by electrical discharge machining – recent development, *Journal of Materials Processing Technology*, 167 (2005), p. 488-493.